

The Leader of Domestic Motion Control Solution Provider

# ADTECH

## Product Selection Guide

### ADTECH (SHENZHEN) TECHNOLOGY CO., LTD.

Address: 5th Floor, Tianxia IC Industrial Park, Majialong, Yiyuan Road, Nanshan District, Shenzhen City, Guangdong Province, P.R.China

Tel : +86-755-2609 9116

Fax: +86-755-2672 2718

Mob: +86 139 0296 6285

Email: export@machine-controller.com

Website: www.machine-controller.com

www.adtechen.com

### Headquarter (Shanghai)

#### Shanghai STEP Electric Corporation.

Add: No 289, Xinqin Road, Jiading District

Shanghai, China. Post Code: 201801

Robot Factory

Add: No.1560, Siyi Road, Jiading District

Shanghai, China. Post Code: 201801

### ADTECH National Agents :

#### Turkey Agent

**Caner Yüksel**

Uzunçayır Cad. No:39 Kadıköy İş Merkezi C1  
Blok D:12 Hasanpaşa, Kadıköy/İstanbul Kroki

#### Vietnam Agent

**HÀ QUANG KHẢI**

66/328 - Phạm Văn Thuận- Tổ 2- Khu Phố 1  
- Phường Tân Mai - Biên Hòa - Đồng Nai

#### India Agents

**Adnan**

70/71 Mohammedi Manzil,  
next to ruhani hotel,  
Mohammedali road,  
Masjid Bunder, Mumbai 400003

#### Korea Agent

대표 이희

부산시 금정구 금사로 206 번지 609-845

#### Sandeep

7, Krishna Estate, Plot No. 3606,  
Phase-4, GIDC Vatva,  
Ahmedabad-382445

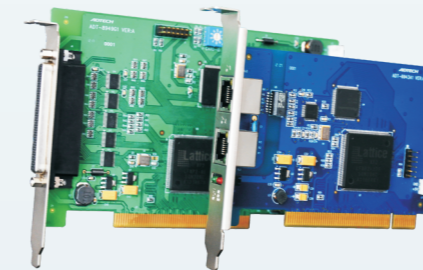

Motion Control Card



Motion Controller



Servo Motor/Driver



Industrial Robot

# Contents

## Motion Control System

### Motion Control Platform

ADT-TV5600DJ .....	04
RC400 4 Axis Robot Drive & Control System .....	06
ADT-TP3540 4-Axis Motion Controller (Touch Screen) .....	08
Motion Control Card .....	10

### Servo/Step Series

Servo Driver .....	12
Servo Motor .....	13
Step Motor & Driver .....	14

### Industry Application Controller

CNC Spring Controller .....	15
Brush Making Controller .....	17
Dispensing Controller .....	19
Flame/Plasma Cutting Controller .....	20



As China's leading motion control solution supplier, ADTECH establishes 2 product systems : motion control system (motion controller, stepper & servo driver, motor and industry application software) ; CNC equipment ( industrial robot, teaching lathe & miller, etc.) , widely used in machines, plastic industry, aerospace, medical instrument, electronic assemble, metal cutting, daily use chemical industry and so on, ADTECH is becoming a typical brand in motion control application area.

ADTECH has set up liaison office in nearly 10 major cities in China, service center in more than 30 cities, building up global sales & service network, ADTECH products have been sold to more than 103 countries including Europe & America, the middle east, southeast Asia, Hongkong, Taiwan and so on.



Shenzhen Head office



Shenzhen sales centre



ADTECH Hunan factory



Hunan Yamaha production line

# Motion Control Platform

- Wood Processing CNC controller .....21
- Turning/Lathe CNC controller .....22
- Milling/Drilling CNC controller .....23
- Punching CNC controller .....24
- Engraving CNC controller .....25
- Color screen series key machine system .....26
- Robots Instant Selection Table.....27
- SA1400 Welding Robot.....28

## ADT-TV5600DJ



### Control function

- ◆ 2-6 Axis interpolation , Space linear、Space arc、Space oval.
- ◆ Using the algorithm of speed forward , Automatic arc corner speed.
- ◆ Support : Modbus ASCII、ModbusRTU and Modbus TCP communication protocol.
- ◆ Support designed to solve the problem of Non-standard process LUA script functions.
- ◆ Axis of rotation radius compensation.

### IO

- ◆ All the OMC8848 are photo-isolator , input voltage 12-24V.
- ◆ Output type : NPN open collector 5-24VDC , Rated current 0.5A , Max current of single road 1A.
- ◆ Every axis hardware plus or minus limit、or home and stop、start button (Limit input can be set up as a general purpose invalid input).

Dispensing machine application industry

- ◆ **Acoustic industry** : Speakers, Buzzer, Acoustics, Headphones.
- ◆ **Inductance industry** : Small transformer, SMT transformer, Inductance, Relays, Small coil motors.
- ◆ **Communications** : Mobile phone keys, Cell phone casing adhesive, Inter phone, Telephone, Fax machine.
- ◆ Computers, Digital products, Digital cameras, MP3, MP4, Electronic toys, Adhesive.
- ◆ Switches, Connectors, Wire, Plug wire.
- ◆ **Electronics** : Integrated circuits, LCD screens, Potting glue machine.
- ◆ **Optics** : Optical lens, Bald, Magnetic.
- ◆ **Battery** : The battery box of sealant , Battery shell potting glue machine , Battery back cover dispensing machine.
- ◆ **Craft** : Trademark fixed adhesive , Sign a glue machine , Small adorn article point crystal glue.
- ◆ **Auto parts electronics industry** : Car doors and Windows and glass glue.

Dimension

Unit : (mm)

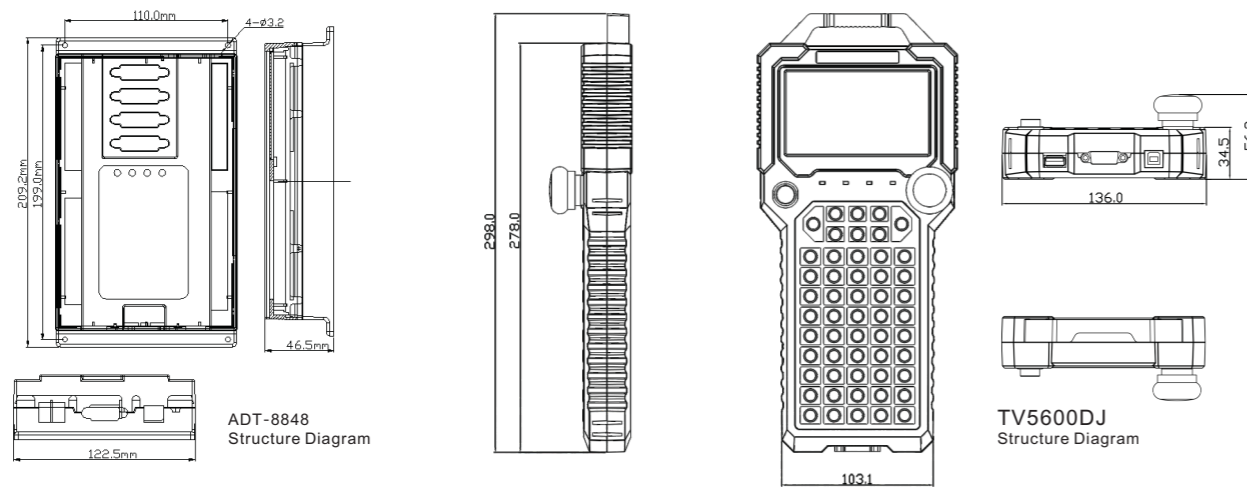

Function Introduction

- ◆ 8 inch touch screen;
- ◆ SCARA robot dedicated operation definition;
- ◆ AR language support robot, G-code programming;
- ◆ Support for absolute, incremental brand motor at home and abroad, including Sanyo, Panasonic, Tamagawa, motor specifications pick;
- ◆ Advanced vibration suppression techniques, processing more stable;
- ◆ Parameter self-tuning technology, no longer have to worry about the parameter debug;
- ◆ Circular interpolation of 3D space technology;
- ◆ Continuous motion speed adaptive technology;
- ◆ Spline teach technology;
- ◆ Direct support to three-dimensional simulation display on the handset;
- ◆ SCARA flexible calculation of coordinate transformation and pose.
- ◆ Supports a variety of communication methods, network, USB, U ... ..
- ◆ The built-in soft-PLC (IEC61131-3) < option package >;
- ◆ NURBS interpolation technique < option package >;
- ◆ Off-line programming
- ◆ Remote monitoring
- System testing, Diagnostics, alarms, operation log

Specifications of products

		Model	RC400	
Flex Pendantdisplay	Display		8 Inch	
	Teaching method		Data input by manual(coordinate value input) Cartesian coordinate teaching. Offline teaching(Input data outside)	
	Tracking program input		AR language	
	Data cable		5M	
	Size/weight		355mmX248X70mm(teaching dependent) / 2kg	
	Power supply		24V DC	
	Data exchange method		USB	
Driver and control all-in-one machine	Axis control function	Control axis		4 axis
		Drive motor type		AC servo motor(Support TAMAGAWA,PANASONIC,SANYO,ADTECH etc.)
		Support encoder type		Incremental/ absolutely AB phase encoder
		Position control period		8K/16K
		Movement/ servo control function		linear interpolation, arc interpolation, continuous tracking, all kinds of acceleration and deceleration Arch movements
		Coordinate system		Joint coordinate system, Cartesian coordinate system
		Position unit setting		Degree.mm
		Off line movements		total absolutely control position ( need not homing original poin)
	Program	Program environments		AR language ,G-code,IEC61131-3
		Storage method		U-disk, SD cards
	External input and output	Standard I/O	I/O input	36 channel
			I/O output	24 channel
		Output communication	RS-232	3 channel
			RS-485	1 channel
			Ethernet	1 channel
	Basic specification	Output size		400mmX260mmX160mm (controller)
		Weight		10 Kg
		Power cable		1.5M
		Power supply		220V AC
	Working temperature		0~40 degree	
	Working humidity		under 90% RH	
Storage temperature		-10~65 degree		

Motion Controller

ADTECH Motion controllers adopt industrial advance & high-speed microprocessor ARM, VLSI programmable device FPGA. By far, our motion controllers have been successfully applied on hundreds kinds of machines in more than 50 countries and nations.

Functions



Applies 400MHz main frequency, 32 bits of RISC CPU; 4-axis servo/step control; Kinds of single-axis or multi-axis motion, it can work without PC; High resolution true color display 5.6 inch display can supply user with a friendly human-machine interface; U disk connection It can make more convenient to exchange data with other equipments; R232 serial port makes the controller can communicate with any equipments which is compatible with standard R232; I/O ports 32 channels of optical coupling input, 16 channels of optical coupling output, 4 channels of pulse/direction signal output; Super program memory capacity, up to 256M, which can meet kinds of programs' running and processing easily; Random 2-4 axes hardware linear interpolation, random 2 axis software arc/oval/continuous interpolation.

Features

- ◆ 5.6 inch high resolution true-color display;
- ◆ 4-axis servo/step control;
- ◆ Adopts ARM9 processor, the main frequency be up to 400M;
- ◆ 32 channels of digital input;
- ◆ 16 channels of digital output, with short circuit protection, the max output current be up to 1A;
- ◆ Multi communication interface: RS232, U disk, USB ;
- ◆ Linear acceleration/deceleration.

# Motion Control Card

## Accessories

Data line



USB download line



Terminal board

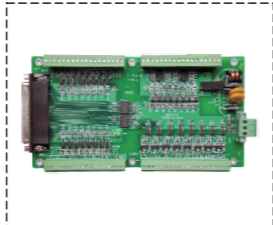

## Applications

Electronic automation processing, assembly, testing, semi-conductor, LCD processing, checking; laser cutting, engraving, laser marking; biological and medical auto-sampling and processing equipment, special CNC machine tools.

## Summarization

Motion control card is designed for step and servo motor control, which is installed in PC. (It is similar to graphics card and base on PC platform). Motion control card and PC consist of the master-slave structure: PC is in charge of human-computer interface's management and other management. (Such as computer outer input, pictures indicate, internet communication, etc.); Motion control card is in charge of all details of motion control aspect. (Such as acceleration and deceleration processing, pulse output, linear and circular interpolation, origin limits monitoring, complicated track control, etc.)

## Principle Structure

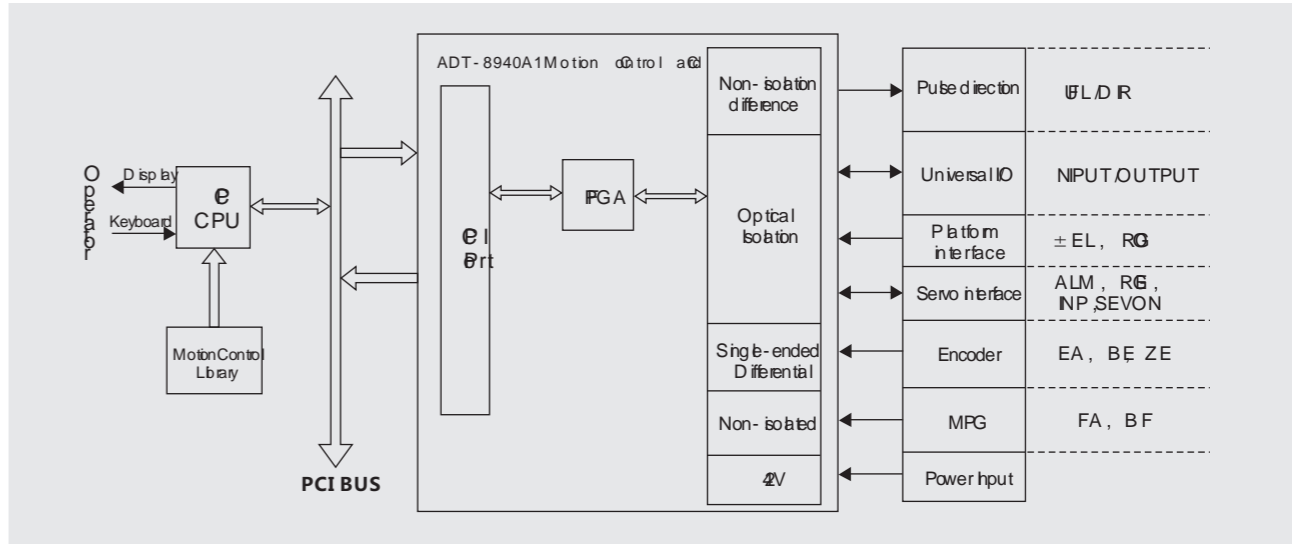

## Applications

Engraving machine, cutting machine, laser engraving, laser cutting, graphic machine, dispensing machine, welding machine, drilling machine, punch machine, automatic detection of electronic fitting, automatic detection of press, cutting and welding of semiconductor, all kinds of NC cutting, industrial robot, measure of space coordinates, biological and medical auto-sampling and processing equipment.

Features Reference Sheet for Multi-axis Motion Control Card

	PCI bus										RTEX bus			PC-104 bus		
Pictures																
Model	ADT-8920A1 ADT-8940A1	ADT-8940G1	ADT-8948A1	ADT-8949G1	ADT-856	ADT-8960	ADT-8912A1	ADT-6943A1	ADT-834	ADT-836						
Number of axis	2/4	4	4	4	6	6	12	32	4	6						
Digital input	24/40	36	32	36	32	32	68	16*N	32	48						
Digital output	12/16	32	32	32	16	16	24	16*N	32	32						
Encoder	0/4	4	4	4	6	6	12	32	4	6						
Line interpolation	Any 2-4 axis	Any 2-4 axis	Any 2,3 axis	Any 2-4 axis	Fixed 2-6 axis	Any 2-6 axis	Any 2-12axis	Any 2-6 axis	Fixed 2-4 axis	Fixed 2-6 axis						
Circular interpolation	Software arc	Software arc	Hardware arc	Any 2,3 axis	Hardware arc	Software arc	Software arc	Software arc	Hardware arc	Hardware arc						
Hardware cache	2M hardware cache achieved	2M hardware cache achieved	One command cache achieved	Ten thousand segment massive cache	One command cache achieved	2M hardware cache achieved		512 segment cache	One command cache achieved	One command cache achieved						
Pulse frequency	2MHz	2MHz	4MHz	5MHz	4MHz	2MHz	2MHz	8MHz	4MHz	4MHz						
Basic functions	T, S-type acceleration and deceleration; to achieve changing speed and target position; hardware stop function; multiaxial with move/stop at the same time; latched position; handwheel function	T, S-type acceleration and deceleration; to achieve changing speed and target position; hardware stop function; multiaxial with move/stop at the same time; latched position; handwheel function	Symmetric and asymmetric T, S-type acceleration and deceleration; continuous interpolation function; to achieve changes in the speed and target position; fixed or non-fixed line speed mode; position latch functions; hardware emergency stop function; signal filtering	Symmetric and asymmetric T, S, E, C-type acceleration and deceleration; continuous interpolation function; spline function; gantry position latch function; to achieve changes in the speed and target position; hardware stops; cache increase output control function; simultaneously control functions; signal filtering	Symmetric and asymmetric T, S-type acceleration and deceleration; to achieve change speed and target position; manual latched position; manual deceleration function; with 16 configurable input/output IO; handwheel function	T, S-type acceleration and deceleration; to achieve change speed and target position; manual latched position; manual deceleration function; with 16 configurable input/output IO; handwheel function	T, S-type acceleration and deceleration; arbitrary 2-12 axis linear interpolation; to achieve change speed and target position; probe function; 8-channel high-speed probe in response to input	T, S-type acceleration and deceleration; support position, speed and torque control modes; position latch function; to achieve changes in the speed and target position; fixed or non-fixed line speed mode; position latch function; hardware emergency stop function; signal filtering	Symmetric and asymmetric T, S-type acceleration and deceleration; continuous interpolation function; variable ring function; to achieve changes in the speed and target position; fixed or non-fixed line speed mode; position latch function; hardware emergency stop function; signal filtering	Symmetric and asymmetric T, S-type acceleration and deceleration; continuous interpolation function; variable ring function; to achieve changes in the speed and target position; fixed or non-fixed line speed mode; position latch function; hardware emergency stop function; signal filtering	Symmetric and asymmetric T, S-type acceleration and deceleration; continuous interpolation function; variable ring function; to achieve changes in the speed and target position; fixed or non-fixed line speed mode; position latch function; hardware emergency stop function; signal filtering					

ADTECH Servo Series

Accumulation: The independent research and development experience of six years of servo products. Design Maturity, Scale Production, Rigorous Testing, Quality Assurance, Cost-Effective.  
 Control variety: Position control, Speed control, Torque control; Position/Speed, Position/Torque mixed control, New-Four sections of the internal velocity and internal position control, which achieved speed and location of the segment control.  
 Variety of models: Power from 100W to 5500W; Low-inertia, Middle-inertia, High-inertia : Voltage have 220V single-phase, 220V three-phase, 380V three-phase series products.  
 High performance: Rest to 3000RPM time less than 20MS, seismic capability, short response time.  
 Operation easy: Adopt the current loop, velocity loop, position loop closed-loop control, adaptive ability; serial RS-232 communications, computers, real-time monitoring of operating waveforms and operating results.  
 Passed certificates: ISO9001, CE.

Related Product Introduction

QS1 Series Servo Driver (Economical Type)

Power range: 0.75KW~1.5KW

With the torque, speed, location, point-to-point positioning and hybrid switching functions;  
 Built-in 4 sections of the location positioning control instructions, free design point-to-point positioning control;  
 Adopt intelligent space vector control algorithm (SVPWM) to produce torque greater than the ordinary PWM, quieter;  
 Position loop has position smoothing system to make the action smoothly;  
 With the rated speed of 3000RPM, and an optional (1024, 2048, 2500) p/r encoder feedback pulse accuracy;  
 Three times overload with a load capacity;  
 Protection features: over current, over voltage, overheating and encoder fault etc.



QS1

QS7 Series Servo Driver (Universal Type)

Power range: 0.1KW~5.5KW

Voltage input: AC200V-230V, use single-phase/two-phase or three-phase input  
 Position/Speed/Torque control mode;  
 Built-in single axis positioning control function (degree of control, zero return, auto-loop positioning control, position teaching);  
 Support Modbus communication protocol, multi-axis bus control (communication interfaces: RS-485/RS-232)  
 Perfect Protection Function: over-current, over-voltage, over-heating and encoder bug, etc.



QS7

QS2 Series Low-Voltage Servo Driver

Power range: 0.1KW – 0.4KW

Voltage input: 24-80V DC,  
 Built-in variety of algorithms, rich control mode, easy to setup, perfect protection, compact size, cost-effective  
 Support Modbus communication protocol, multi-axis bus control (communication interfaces: RS-485/RS-232)



QS2

Applications

CNC equipment, textile machinery, automation equipment, woodworking engraving machine, spring making machine, brush making machine, etc.

## Servo Motor

### ADTECH Servo Motor

High-Overload Ability: three times overload to prevent the abrupt burn motor;  
 Low Temperature: the temperature is less than 60 degrees in the rated speed & torque;  
 Low Noise: running noise is less than 38dB in the rated speed & torque.

### Related Product Introduction

#### ACH Series Standard Servo Motor

Power Range: 0.2KW~5.5KW;  
 Torque Range: 0.63~15.0N.m;  
 Speed Range: 1000r/min~3000r/min;  
 Customized Products: Brake, Oil seals;  
 Axis Type: Round shaft, Keyway.



#### MRMS Series High-performance AC Servo Motor

Power Range : 0.2KW-1KW  
 Torque Range : 0.63-3.3NM  
 Speed Range : 3000r/min  
 Customized Products: Brake, Oil Seal  
 Axis Type: Round Shaft ,Keyway



#### ACL Series Low-Voltage AC Servo Motor

Power Range : 0.1KW-0.4KW  
 Torque Range : 0.22-1.27NM  
 Speed Range : 3000r/min-4500r/min  
 Customized Products: Brake, Oil Seal  
 Axis Type: Keyway



#### ACN Series Servo Motor

Power Range : 0.05KW-0.2KW  
 Torque Range : 0.16-0.64NM  
 Speed Range : 3000r/min-4500r/min  
 Customized Products: Oil Seal  
 Axis Type: Keyway



## Step Motor/Driver

### Step Motor and Step Driver

ADTECH provides solution for all series step motor/step driver. We developed high-performance step motor & driver based on using DSP system & making space vector; sine wave current output smoothly, motor noise suppression & vibration effectively; low heat, high-speed and torque output improve motor; prolong using life; in especially, reduce the low/medium frequency vibration greatly, improve low-speed steady; at the same time, the exquisite design, improve integration, reduce size and weight of product, which can matching the corresponding model of the domestic and international brands.

### Related Product Introduction

#### Step Driver:

##### 2-phase Step Driver:

Current Range: 2.0A~8.0A;  
 Voltage Range: 20VAC~60VAC; 24VDC, 40VDC, 80VDC;  
 Subdivision: Provides 15 grades of the general micro-step subdivision setting value, the maximum subdivision no. is 512



##### 3-phase Step Driver:

Current Range: 2.0A~8.0A;  
 Voltage Range: 80VAC~110VAC; 24VDC, 40VDC, 80VDC;  
 Subdivision: Provide 15 grades of the general micro-step subdivision setting value, the maximum subdivision no. is 512.



#### Step Motor:

##### 2-Phase Step Motor :

Size Range: 42~130MM  
 Holding Torque: 0.21~40N.m

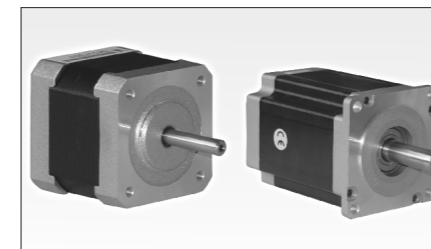

##### 3-Phase Step Motor :

Size Range: 56~130MM  
 Holding Torque: 0.45~35N.m

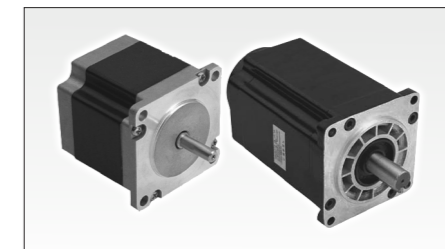

## Industry Application Controller-CNC Spring Controller

As a built multi subdivision standard industrial for CNC application control system, ADTECH launching advanced solutions for specified industrial. On a mature of leading motion control platform, ADTECH provide the solution of industry application controller for clients! In especially, Motion control system for spring making machine, brush making machine, dispensing machine, CNC cutting machine, welding machine, spraying machine, laser making machine and so on, which are reach to the leading level in domestic, and it wins a widely reputation of customers.

### Features

- ◆ Adopt form programming , easy to operation
- ◆ Support on-line programming easy to debugging
- ◆ Probe with fast response to ensure high-precision
- ◆ Complete information system
- ◆ Can be extended to external MPG and easy to debug for large machine
- ◆ Support USB transfer, U disk copy and easy to upgrade and copy program
- ◆ Support Chinese-English shift, with high-adaptability
- ◆ Cam, sending lines turn-core work simultaneously with sending wire precision  $\pm 0.01\text{mm}$  & accuracy  $\pm 0.1$  degrees of camshaft & the spindle of turn-core. Each rotating shaft has no zeroing function alone.

### Related Product Introduction

#### ADT-TH08HA-D01 2-3 Axis Controller for Compression Spring Machine



5.7 Inch industrial LED display;  
English/Chinese interface, applicable to different countries;  
Support 2-3 axis servo control;  
Support 4-8 groups of probe cylinders;  
Specifically to 8 type compression spring machinery;  
MPG debugs processing function;

#### ADT-TH08R-A02 2~4 Axis Controller for Compression Spring Machine



10.4 inch Industrial color LCD display;  
English/Chinese interface, applicable to different countries;  
Support 2-4 axis servo control;  
Support 4-8 groups of probe cylinders with quick response;  
MPG debugs processing & test processing function;

#### ADT-CNC820B-A02 4 Axis Controller for Spring Machine      ADT-CNC820B-B02 6 Axis Controller for Spring Machine



15 inch color LCD display;  
Command form programming, display in English /Chinese with simple & intuitive programming;  
Support directly editing to input data for programming after move each axis to target location  
By MPG or panel ;

#### ADT-TH1204-b00 12 Axis Controller for Spring Machine

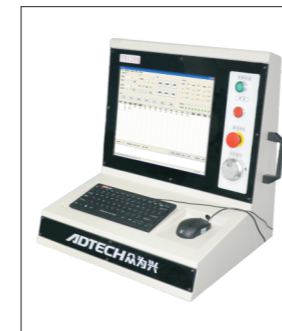

Command form programming, display in English /Chinese with simple & intuitive programming;  
Support directly editing to input data for programming after move each axis to target location;  
Support online editing –can support real-time control without shut down when processing;  
Support multi-axis working simultaneously with linear mode precision  $\pm 0.01\text{m}$ , rotating mode precision  $\pm 0.1$  degree . Each rotating shaft has no zeroing function alone.

# Brush Making Controller

## Features

- ◆ Support english operation system;
- ◆ Tufting speed can reach 700 hole / min;
- ◆ Support self-colored and bicolor hair planting ;
- ◆ Maximum storage of 2000 processing files with each up to 100,000 holes;
- ◆ Flash function enables fast and convenient copy of processing files among different machinery;
- ◆ Support hand-held box operation;
- ◆ Short circuit protection for output, with long product life;
- ◆ Be able to adjust the main shaft processing speed by controller;
- ◆ Be able to control the height of hair-planting, suitable for various different workpiece;
- ◆ Signals of each control shafts are lead out independently, it is convenient to connect the wire;
- ◆ With various of processing type, and applied to different situation, Automatic, semi-automatic test-work processing mode are optional;
- ◆ Various of editing function, user input data in simple and fast;
- ◆ Support user data,automatic generation, simple and easy to use.

## Related Product Introduction

### ADT-ZM210 2 Axis Brush Making Controller



Self-colored display screen,240\*128 resolution;  
Support self-colored and bicolor hair planting;  
Tufting speed can reach 500 holes/ min;  
Maximum storage of 2000 processing files with each up to 700 holes.

### ADT-ZM300B 3 Axis Brush Making Controller



5.7 inch LCD self-colored display screen;  
3 axis step and servo motor control;  
Tufting speed can reach 700 holes/ min;  
Maximum storage of 2000 processing files with each up to 100,000 holes.

### ADT-ZM400B 4 Axis Brush Making Controller



5.7 inch LCD self-colored display screen;  
Support self-colored and bicolor hair planting;  
Tufting speed can reach 700 holes/ min;  
Maximum storage of 2000 processing files with each up to 100,000 holes.

### ADT-ZM310 3 Axis Brush Making Controller



Self-colored display screen,240\*128 resolution;  
3 axis step and servo motor control Maximum storage of 2000 processing files with each up to 100,000 holes;  
Support Z axis 360 degree unlimited rotation.

### ADT-ZM410 4 Axis Brush Making Controller



5.7 inch LCD self-colored display screen;  
4 axis step and servo motor control;  
Tufting speed can reach 700 holes/ min;  
Maximum storage of 2000, processing files with each up to 100,000 holes.

### ADT-ZM410Y 4 Axis High-speed Toothbrush Making Controller



5.7 inch LCD self-colored display screen;  
2+2 axis step and servo motor control ;  
Tufting speed can reach 700 holes/ min;  
Maximum storage of 2000 processing files with each up to 100,000 holes.

### ADT-ZM500B 5 Axis Brush Making Controller



5.7 inch LCD self-colored display screen;  
5 axis step and servo motor control;  
Tufting speed can reach 700 holes/ min;  
Maximum storage of 2000 processing files with each up to 100,000 holes.

### ADT-ZM510 5 Axis Brush Making Controller



5.7 inch LCD self-colored display screen;  
5 axis step and servo motor control;  
Tufting speed can reach 700 holes/ min;  
Maximum storage of 2000 processing files with each up to 100,000 holes;  
Be able to control the height of hair-planting ,suitable for various shape of workpiece.

## Color Touch Screen Series

### ADT-ZM620 4-6 Axis Brush Making Controller



10.4 inch color LCD display screen;  
4-6 axis step and servo motor control;  
Support mutli-head for tufting and drilling;  
Through the pedal switch for unloading workpieces , safe and convenient operation;  
Main shaft processing speed can be adjust by programming, work table speed can also be adjusted with it synchroly.

### ZM220—Brush Making Controller



5.6inch true-color display, touch screen, friendly interface;  
Slim volume, simple structure , easy to wire;  
2 axis step and servo motor control;  
Support U disk read and write, program updates;  
Easy and convenient to teach, support CSV directly importing processing data and MPG teach;  
Support interpolation processing and index acceleration/deceleration movement;  
Support software/hardware limit with more safe & reliable system;  
Graphic pattern teach with intuition & convenience;  
Support processing path display track;

### ZM320- Brush Making Controller



5.6inch true-color display, touch screen, friendly interface;  
Slim volume, simple structure , easy to wire;  
3 axis step and servo motor control;  
Support U disk read and write, program updates;  
Easy and convenient to teach, support CSV directly importing processing data and MPG teach;  
Support interpolation processing and index acceleration/deceleration movement;  
Support software/hardware limit with more safe & reliable system;  
Graphic pattern teach with intuition & convenience;  
Support processing path display track;

### ZM420- Brush Making Controller



5.6inch true-color display, touch screen, friendly interface;  
Slim volume, simple structure , easy to wire;  
4 axis step and servo motor control;  
Support U disk read and write, program updates;  
Easy and convenient to teach, support CSV directly importing processing data and MPG teach;  
Support interpolation processing and index acceleration/deceleration movement;  
Support software/hardware limit with more safe & reliable system;  
Graphic pattern teach with intuition & convenience;  
Support processing path display track;

## Dispensing Controller

### Features

- ◆ Support three axis space straight line interpolation , two axis arc and ellipse interpolation etc;
- ◆ Real time multi-task control technology and hardware interpolation technology ensure high reliability;
- ◆ 3340: 32 lines input, 16 lines output; 8848: 34 lines input, 18 lines output; 8860: 86 lines input, 40 lines output; 3540: 32 lines input, 16 lines output; 8540: 25 lines input, 8 lines output, fully optical coupling control, excellent anti-interference performance
- ◆ Support control of 4-8 adhesive injecting terminals;
- ◆ Use speed perspective arithmetic, automatic smooth corner speed, ensuring smooth process;
- ◆ Have abundant instruction sets: motion instructions such straight line, arc, single point and ellipse, and instructions such as port output, waiting input, delay pause, selecting glue gun, resetting motor, etc;
- ◆ Advanced editing functions such as batch modification, array copy, graph shift, graph zooming, automatic rounding and common graph library ect.
- ◆ Importing computer graphs: convert the graphs in the computer to PLT files or TCF files or G code files, and then convert to process files of adhesive injecting machine through the controller; each process file can save 100,000 process points
- ◆ Graph display function: display the graphs in the process files intuitively and display the process track dynamically in real time;
- ◆ Track lag adhesive open and advance adhesive close function, eliminating the adhesive stacking problem at the start point and end point;
- ◆ Wire drawing function: eliminating glue adhesive problem
- ◆ Support cycle processing, single processing, automatic processing and step processing ect
- ◆ File instruction and edit function, provide advanced edit functions such as batch modification, array copy, graph shift, graph zooming and automatic rounding; common graph library is also available;
- ◆ Flash memory reading-writing function: read and write process files in flash memory disk;
- ◆ Convenient help system, calling out help document by pressing shift+F1 in any interface.

### Related Product Introduction

#### ADT-TV5500DJ 2-4 Axis Dispensing Controller (Split Type)



3D processing graphic , support PLT,TCF file;  
Support instruction edit function and match with common graphic library;  
Smooth track motion, speed perspective arithmetic;  
Have abundant instruction sets, be able to satisfy all kinds of complex dispensing processing;  
High performance-price.

#### ADT-TP3340DJ 2-4 Axis Dispensing Controller



5.7 inch touch display screen, interface intuitionistic and clear;  
Data input by instructed type, operation simple and easy to study;  
Support PLT format graphic leading-in function, simplified complex track motion;  
Support double-head dispensing, more efficient;  
With processing graph display function, file storage room reach 256M.

#### ADT-TP3540DJ 2-4 Axis Dispensing Controller



5.6 inch color display, touch type, friendly interface;  
Thinnest volume, convenient connection;  
Support single-double head dispensing;  
Data input by instructed type, operation simple and easy to study;  
Support PLT,TCF file,function, simplified complex track motion;  
With processing graph display function.

#### Full-automatic visual dispensing coating controller

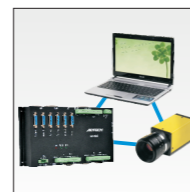

Adopt visual positioning, graph zooming, ensuring the accuracy of dispensing;  
Adopt ADT-8860+PC(or notebook) +CCD program  
Support motion graph editing and instruction and imposition positioning

## Flame/Plasma Cutting Controller

### Features

- ◆ Flame/plasma/laser integration;
- ◆ All of controller support G code format, HC4500 also can support TYPE3 , HC8200 can support ESS1 code;
- ◆ Process modularizaion, user can change the modularizaion of processing move from software;
- ◆ Be able to support wire handheld box , HC6500 can suport wireless romote, convenient to testing;
- ◆ Support USB communication, flash copy, convenient to program update and copy;
- ◆ All of controller have english and chinese, HC4500, HC6500, HC4300 can support language of any country in the world;
- ◆ Software and hardware limited and alarming function, more safe;
- ◆ Customization software and hardware;
- ◆ Multi- graphics library function.

### Related Product Introduction

#### ADT-HC4500 Flame/Plasma Cutting Controller



7 inch industrial color display, ARM processing technology , low power consumption, low cost solution;  
Perfect flame/plasma technology, cut sewing and backlash compensation functions;  
Support type 3 format;  
Friendly human-machine interface, editable graphics library, graphic transform, mutil-language design, online help system;  
Outage and breakpoint memory, back, select point and select line practical function;  
Large storage space, easy to handle big program operation.

#### ADT-HC8200 High-end Type Gantry Flame/Plasma Cutting Controller



The system adopts industrial computer as the processing core and windows operating system, multi-task, mutil-window and multi-thread technology, highly speed processing, conveniently operation and intuitivism;  
15 inch industrial level LCD display , plenty information;  
Perfect flame/plasma/dusting alignment/ plasma mark processing, gas compensation etc;  
Friendly human-machine interface, editalbe graphic libraries, vary graph, multi-language design as well as online helps system;  
Pause, continue, breakpoint & power failure memory, backward, forward and other practical functions;  
Super large storage space, can easily running big procedure.

#### ADT-HC6500 Popular Type Gantry Flame/Plasma Cutting Controller



10.4 inch LCD display , ARM processor technology;  
Perfect flame/plasma/dusting alignment/ plasma mark processing, gas compensation etc;  
Friendly human-machine interface, editalbe graphic libraries, vary graph, multi-language design as well as online helps system;  
Pause, continue, breakpoint & power failure memory, backward, forward and other practical functions;  
Support wireless control by long distant.

## Wood Processing CNC Controller

### Features

- ◆ After over half a century's development, woodworking machinery industry has established a complete system from education, research, development, manufacturing, testing to sales in China. The industry has become one of the important technical equipment industries in our country, playing an important role in the national economy.
- ◆ Wood processing has become a stable process system, with the degree of specialization continuously increasing. The rapid development of computer applications and CNC industry, have had an important role on wood processing technology for innovation, wood processing industry system changes, as well as the development of production processes and product design engineering, promoting woodworking machinery from a purely mechanical products over to automation and intelligent products.
- ◆ CNC technology in the future will go more deeply into many other process areas of the wood processing.

### Deficiencies and problems in the industry

In CNC process of today's woodworking machinery industry, CNC process of woodworking lathe and milling machine is one of the most important content. CNC woodworking lathe and milling system currently used in the vast majority of the industry is not developed specifically for the woodworking industry, so there are many shortcomings and problems:

1. some using SCM, poor stability
2. System process is imperfect, not professional
3. Low processing efficiency
4. High cost for such control systems, and professional staff required for operation

### Related Product Introduction

#### MCK300A Wood Processing CNC Controller



- MCK300A Wood Processing CNC Controller is developed based on Adtech powerful strength.
1. Adopt ARM9 processor and high performance FPGA motion chip, with excellent stability and reliability
  2. 2.7inch LCD color screen, friendly display interface
  3. Support woodworking lathe and milling technology, simple operation
  4. Graphical display and processing real-time tracking function, can intuitively display graphic shape in processing document
  5. The system supports two-pole control, and support pole once and multiple reciprocating processing technology, can greatly improve the efficiency of woodworking lathe and milling machining processing
  6. DXF importing processing function, simplify generation process of processing document
  7. Adopt laser shape scanning directly generate processing code, greatly reduce the operating requirements of the workers
  8. USB communication function, support U disk process file copy and upgrade system, easy maintenance
  9. System diagnostics function make customers can self-diagnose some of the hardware
  10. Wireless remote control

### Vision

Adtech is a leader in the field of motion control in China, not only approved by customers but also favored by many partners. Our company is trying to build the leading brand in the industry. MCK300A Wood Processing CNC Controller is built on the base of Adtech years of research and development strength. It has comprehensive functions, friendly interface, stable performance and easy to operate. it can greatly improve the efficiency of woodworking milling process, greatly reduce the operating requirements of the workers, is a highly cost-effective control system, will shine in woodworking CNC areas.

## Turning /Lathe CNC Controller

### Features

- ◆ With USB, flash and RS232COM communication etc., many kinds of communication modes, can easily realize different data transmission and software update. With network interface, the system supports remote monitoring and transmission process of DNC file;
- ◆ Open CNC platform, capable of customization system according to specific requirements;
- ◆ With complete self-diagnostic function, internal and external real-time display, it will show alarm if any exception;
- ◆ Support additional panel and external handheld box operation, it's convenient to cutter aligner for customers;
- ◆ Macro-variable, programming of macro definition, enable to many kinds of logical relation. Support macro programming with parameter being used, more convenient to user;
- ◆ DXF + G code template function, switching the DXF file to G code for processing automatically;
- ◆ Teaching function: teaching+simple command programming, adopt table teaching mode, easy and direct viewing;
- ◆ Graphic simulation function: display processing program's graph as well as tool's moving track in actual movement, simulate cutting tool process with the machine not running to check whether the program we edit is correct;
- ◆ Multi-interface option: support multi-language interface display, auto alarm when breakdown. Abundant process information display of process time, numbers;
- ◆ Parameter tabulate: The I/O address can be set randomly when the right data is put in the address of configuration table;
- ◆ Built-in PLC core, functions extending flexible.

### Related Product Introduction

#### ADT-CNC4620 2 Axis Turning /Lathe CNC Controller



- 2 axis servo/step motor control;
- Good HMI design;
- Adopt embedded high speed processor and professional customized FPGA motion chip;
- Comprehensive function, support standard G code, DXF file and Macro function;
- With large capacity storage, convenient to customers;
- Adopt high speed high accuracy algorithm to process to get good process effects.

### Features

- ◆ U disk reading function, can be simulated as electronic hard drive to read edit and process datas, satisfying all kinds of large program's workpiece processing;
- ◆ High process speed, can reach 20m/min;
- ◆ Complete, direct viewing of system running status, help user find problems in time, solve the problems easily;
- ◆ Support handheld box and extensional panel, convenient to operate;
- ◆ Support powerful B type macro resolving function, convenient for customers to develop their own motion control programs;
- ◆ DXF + G code template graph resolving;
- ◆ MST code external self define edit, easy to extend customers' functions;
- ◆ 3D graph simulation function;
- ◆ Power down save function, password protection function, screensaver function and so on;
- ◆ Fully compatible with FANUC, mitsubishi G code and many kinds of CAM software( such as masterCAM, UG and so on.);
- ◆ Built-in PLC core, functions extending flexible.

### Related Product Introduction

#### 3-6 axis NC module



3-6 axis step/servo motor control;  
Adopt embedded high speed processor and professional customized FPGA motion ship;  
NC core adopt preliminary treatment perspective track smooth treatment;  
Run smoothly, can get good process effect;  
Comprehensive function, support standard G code, DXF file and macro function;  
Support multi-computer link through Ethernet, and apply in automatic production line assembly line work;  
Equip with IO expansion bus (basic module output 40 points, input 50 points);

#### ADT-CNC4940 4 Axis High Grade Milling/Drilling CNC Controller



10 inch big LCD screen;  
4 axis servo/step motor control;  
Good HMI design;  
Adopt embedded high speed processor and professional customized FPGA motion chip;  
With open interface, flexible to extend;  
Comprehensive function, support standard G code, DXF file and Macro function;  
With large capacity storage, convenient to customers;  
Adopt high speed high accuracy algorithm to process to get good process effects;  
With high speed network data interchange interface.

#### ADT-CNC4640 4 Axis Milling/Drilling CNC Controller



4 axis servo/step motor control;  
Good HMI design;  
Adopt embedded high speed processor and professional customized FPGA motion chip;  
Comprehensive function, support standard G code, DXF file and Macro function;  
With large capacity storage, convenient to customers;  
With smart teaching, convenient and easy to use;  
Adopt high speed high accuracy algorithm to process to get good process effects;  
With high speed network data interchange interface.

#### ADT-CNC4960 6 Axis Milling/Drilling CNC Controller



10 inch big LCD screen;  
6 axis servo/step motor control;  
Good HMI design;  
Adopt embedded high speed processor and professional customized FPGA motion chip;  
With open interface, flexible to extend;  
Comprehensive function, support standard G code, DXF file and Macro function;  
With large capacity storage, convenient to customers;  
Adopt high speed high accuracy algorithm to process to get good process effects;  
With high speed network data interchange interface.

### Features

- ◆ Support multi-language option, cost effective;
- ◆ With CAM template guide edit function, easy to use;
- ◆ Support CAM file resolving process;
- ◆ Macro-variable, programming of macro definition, enable to many kinds of logical relation. Support macro programming with parameter being used, more convenient for user to program;
- ◆ With complete self-diagnostic function, internal and external real-time display, it will show alarm if any exception.

### Related Product Introduction

#### NCT-02 2 Axis Punching CNC Controller



Support X Y 2 axis motion;  
Easy to learn, friendly interface, convenient operation;  
Can preview process track and real-time following;  
Support twice relocation and clamp avoid function, realize palte no dead zone process;  
With single punch, continuous punch, step punch etc. different kinds of punching mode, increase the process efficiency;  
Can recognize CAD convert code, compatible with usual punching machine software code, support CAM template programming;  
With complete self-diagnostic function, internal and external real-time display, it will show alarm if any exception.

#### NCT-04 4 Axis Punching CNC Controller



Add T axis die change control and C axis die rotary control;  
Max support 36 working position, can customize mould library;  
Easy to learn, friendly interface, convenient operation;  
Can preview process track and real-time following;  
Support twice relocation and clamp avoid function, realize palte no dead zone process;  
With single punch, continuous punch, step punch etc. different kinds of punching mode, increase the process efficiency;  
Can recognize CAD convert code, compatible with usual punching machine software code, support CAM template programming;  
With complete self-diagnostic function, internal and external real-time display, it will show alarm if any exception.

## Features of System

- ◆ Support Multi-language ,More economic
- ◆ CAM mode guiding editing function, easy to use
- ◆ Support CAD file explanation processing
- ◆ Macro-Variable、 Macro definition Programming, realize kinds of logical relationship. Support to evoke the Macro-program with parameter, make more convenient to program.
- ◆ Complete Self-diagnose function, Real –time display the Status of Internal/External. Once abnormal, alarms.

## Product's Introduction

### DK300A 3 Axis CNC Engraving System



Control Axis, control X, Y, Z, axis,  $\mu\text{m}$  interpolation accuracy  
 Support several kinds of communications (USB,U disk, RS232COM),easy for user to realize different data transmitting and software upgrade.  
 With network port, support remote control and DNC file transmitting processing  
 Open platform, customize the system according to customer's demand  
 Complete Self-diagnose function, Real display the Status of Internal/External. Once abnormal, alarms  
 Support to use Additional Panel and Handheld Box, convenient for Tool Setting  
 Macro-Variable、 Macro definition Programming, realize kinds of logical relationship. Support to evoke the Macro-program with parameter, make more convenient to program.  
 DXF+G code mode function, change the DXF to G code processing automatic  
 Support the generated working file by MasterCAM, Type 3, ArtCam, UG, PROE software;  
 Pre-treat motion processing with rapid and intelligent speed, processing stable;  
 Teaching Function: Teaching+Command Program , apply the form teaching means, simple and direct  
 Graphic Simulation Function: Show the graphic of processing program and tool's moving track when in actual running; without control machine's running but do the processing of simulation tool path; check editing processing program true or false.  
 Multi-Interface Options  
 Supports multilingual interface display, automatic fault alarm. Rich processing information display, processing time, number of pieces  
 Parameter Tabular: Randomly sets the Input/output Address, only need to write the corresponding value in the Address Bar of the configuration table.

## Color screen series key machine system

With 7 inch color LCD display screen, humanized operation interface, beautiful, information and clear, easy to operate;  
 Supports 2-4 axis stepper & servo motor control.  
 Support U disk read and write, to support hard and soft limit , support handwheel function ; functional diversification , can process a variety of mainstream keys, easy customization ;  
 Key parameters inputing use CAM way to simplify the programming step, the program inside needn't enter the key process parameters;  
 Tips can be refered while operating system, use easily; increasing 26 letters of the alphabet code , can handle both coded numbers and letters .

### KY260A CNC key machine system



Using ARM + FPGA high-end hardware platform to improve stability and efficiency of the system itself;  
 Supports two-axis milling and general milling teeth function, can process simple accessories of lockmaking industry;  
 With the functions of key -coded jump-select processing, custom processing, screening generated, conditional judgment, special processing, automatic grouping, automatic generation, etc;  
 The specific products which is based on milling system development, with the characteristics of low cost, functional, versatile, high efficiency, small size, easy to operate, easy to use, etc;  
 Can be processed with lines according to the special requirements of customers;

### KY360A CNC key machine system



Using ARM + FPGA high-end hardware platform to improve stability and efficiency of the system itself;  
 Most of common key can be processed in key processing industry, as keys with within bilateral, external bilateral, snake, double-deck, etc; Can process common accessories of lockmaking industry;.  
 With the functions of key -coded jump-select processing, custom processing, screening generated, conditional judgment, special processing, automatic grouping, automatic generation, etc;  
 The specific products which is based on milling system development, with the characteristics of low cost, functional, versatile, high efficiency, small size, easy to operate, easy to use, etc;  
 Can be processed with lines according to the special requirements of customers;

### KY460A CNC key machine system



Using ARM + FPGA high-end hardware platform to improve stability and efficiency of the system itself;  
 Most of common key can be processed in key processing industry with double power head, as keys with within bilateral, external bilateral, snake, double-deck, etc; Can process common accessories of lockmaking industry;  
 With the functions of key -coded jump-select processing, custom processing, screening generated, conditional judgment, special processing, automatic grouping, automatic generation, etc;  
 The specific products which is based on milling system development, with the characteristics of low cost , functional, versatile, high efficiency , small size, easy to operate, easy to use, etc;  
 Can be processed with lines and the new special key customization according to the special requirements of customers;

# Robots Instant Selection Table

Model		ADT-AR3215	ADT-AR4215	ADT-AR5215	ADT-AR6520	ADT-AR7520	ADT-AR8520	ADT-600P4G	Model	SD500	SD700		
Diagram									Diagram				
Species		SCARA	SCARA	SCARA	SCARA	SCARA	SCARA	SCARA	Species	Vertical multi-joint	Vertical multi-joint		
Number of axes		4	4	4	4	4	4	4	Number of axes	6	6		
Arm length		300mm	400mm	500mm	600mm	700mm	800mm	600mm	Arm length	500mm	700mm		
Axis specification	X axis	Arm length	100mm	200mm	300mm	300mm	400mm	500mm	Range of motion	J1	±170°	±170°	
		Rotation range	±127°	±127°	±127°	±130°	±130°	±130°		±135°	J2	±115°	±115°
	Y axis	Arm length	200mm	200mm	200mm	300mm	300mm	300mm		250mm	J3	+40°~220°	+40°~220°
		Rotation range	±142°	±142°	±141°	±140°	±140°	±140°		±145°	J4	±185°	±185°
	Z axis	Route	150mm	150mm	150mm	200mm	200mm	200mm		300mm	J5	±125°	±125°
	R axis	Rotation range	±360°	±360°	±360°	±360°	±360°	±360°		±360°	J6	±360°	±360°
Highest speed	X axis	600°/S	600°/S	600°/S	375°/S	300°/S	250°/S	257.1°/s	Maximum speed	J1	375°/s	250°/s	
	Y axis	375°/S	375°/S	375°/S	600°/S	600°/S	600°/S	225°/s		J2	375°/s	185°/s	
	X, Y-axis synthesis	4.45m/s	5.5m/s	6.5m/s	7.1m/s	6.8m/s	6.6m/s	3.67m/s		J3	430°/s	290°/s	
	Z axis	1.3m/s	1.3m/s	1.3m/s	1.1m/s	1.1m/s	1.1m/s	0.8m/s		J4	460°/s	460°/s	
	R axis	1667°/s	1667°/s	1667°/s	1500°/s	1500°/s	1500°/s	360°/s		J5	460°/s	460°/s	
Standard Cycle Time	0.5s	0.45s	0.4s	0.55s	0.6s	0.6s	0.6s	J6		600°/s	600°/s		
Repeat positioning accuracy	X, Y-axis	±0.01mm	±0.01mm	±0.01mm	±0.015mm	±0.015mm	±0.015mm	±0.05mm	Repeat positioning accuracy		±0.015mm	±0.02mm	
	Z axis	±0.01mm	±0.01mm	±0.01mm	±0.01mm	±0.01mm	±0.01mm	±0.02mm	Wrist load	Rated	3kg	3kg	
	R axis	±0.005°	±0.005°	±0.005°	±0.005°	±0.005°	±0.005°	±0.02°		Maximum	5kg	5kg	
Rated / max load	2Kg/5kg	2Kg/5kg	2Kg/5kg	5Kg/10kg	5Kg/10kg	5Kg/10kg	5kg	Maximum allowable instantaneous torque	J5	35Nm	35Nm		
R axis allows load moment of inertia (Rated / max)	0.01 kg·m2	0.01 kg·m2	0.01 kg·m2	0.05 kg·m2	0.05 kg·m2	0.05 kg·m2	0.05 kg·m2		J6	24Nm	24Nm		
		0.04 kg·m2	0.04 kg·m2	0.04 kg·m2	0.2 kg·m2	0.2 kg·m2	0.2 kg·m2	User signal line		0.14 sq * 16 lines	0.14 sq * 16 lines		
User signal line		0.2sq * 16 lines, 8 outputs, 6 inputs	0.2sq * 16 lines, 8 outputs, 6 inputs	0.2sq * 16 lines, 8 outputs, 6 inputs	0.2sq * 16 lines, 8 outputs, 6 inputs	0.2sq * 16 lines, 8 outputs, 6 inputs	0.2sq * 16 lines, 8 outputs, 6 inputs	0.12sq * 25 lines	Users pipe		Φ4*4roots	Φ4*4roots	
Users pipe		Φ6*2 roots	Φ6*2 roots	Φ6*2 roots	Φ6*2 roots	Φ6*2 roots	Φ6*2 roots	Φ6*3 roots	Installation		Suits, flip, side-mounted	Suits, flip, side-mounted	
Limit protection		Software limit Mechanical limit (X, Y, Z axis)	Software limit Mechanical limit (X, Y, Z axis)	Software limit Mechanical limit (X, Y, Z axis)	Software limit Mechanical limit (X, Y, Z axis)	Software limit Mechanical limit (X, Y, Z axis)	Software limit Mechanical limit (X, Y, Z axis)	Software limit Mechanical limit (X, Y, Z axis)	Limit protection		Software limit Mechanical limit	Software limit Mechanical limit	
Weight		12.5Kg	13Kg	14Kg	27Kg	30Kg	32kg	39kg	Weight		28Kg	30Kg	

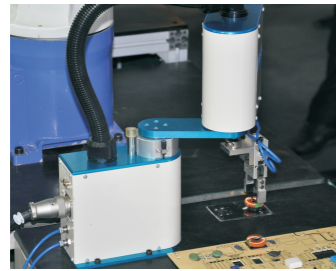

PCBA Plug



Logo inspection



Screwing



Loading



High speed transportation



Plug-in machine PCB loading

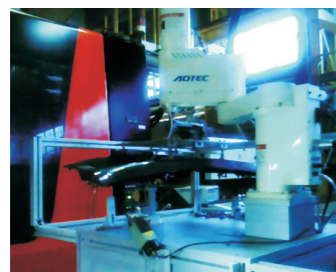

Shear injection nozzle



Deburring



Soldering

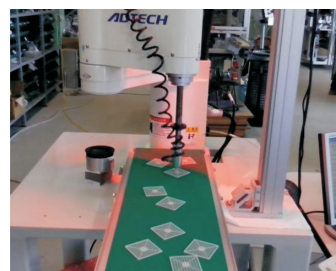

Visual sorting

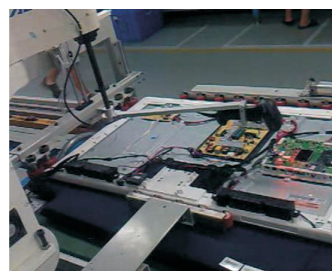

Barcode scanning



Screwing

## SA 1400

### Product Introduction

SA Series robots are compact, small and lightweight, ideal for welding application due to its high stability. It can realize high welding-path accuracy, considerably reduce welding cycle-time, and extend the lifetime of tubes and cables. In addition, SA Series robots can fit in narrow working space and can be floor mounted, inverted or tilted in any angle.

### Main Applications

- ▲ Arc welding
- ▲ Material handling
- ▲ Cutting
- ▲ Palletizing

### Working Space

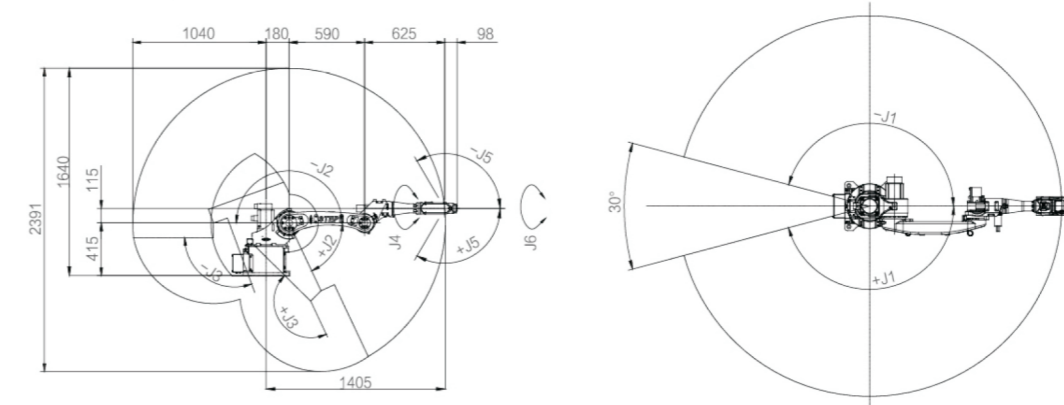

### Technical Specifications

Model	SA 1400	
Wrist Payload	6 kg	
Max Working Radius	1405 mm	
DOF	6	
Max Speed	J1	150° /s
	J2	150° /s
	J3	160° /s
	J4	360° /s
	J5	320° /s
	J6	360° /s
Max Operation Area	J1	± 165°
	J2	+65° ~ -180°
	J3	+160° ~ -110°
	J4	± 170°
	J5	± 120°
	J6	± 360°
The Max Moment Allowable Torque	J5	54 Nm
	J6	23 Nm
Weight	143 kg	
Position Repeatability	± 0.05 mm	
Working Temperature	0 ~ 45°C	
IP Protection Level of Robot	IP40	
IP Protection Level of Control Cabinet	IP30	

